

 *Clima Heating Europe*

CATALOGUE



Outdoor gas heaters





MUZTAG IBIZA

The Ibiza model from the Muztag brand has a very elegant design with the top fully composed by Tempered Glass that allows you to see the flames in all their glory.

Inside it hides a standard size Propane Gas bottle (11KG), the maximum capacity it can reach is 7.3 KW which allows it to provide enough heat to prolong the cool mornings and pleasant summer afternoons, also the flame can be adjusted, the burner comes with volcanic stones.

For storage or protect the heater in case of rain we offer a waterproof cover that fully protects it.

Price: 849,00€ Taxes included (Black)

Price: 875,00€ Taxes included (White)





Technical Specifications

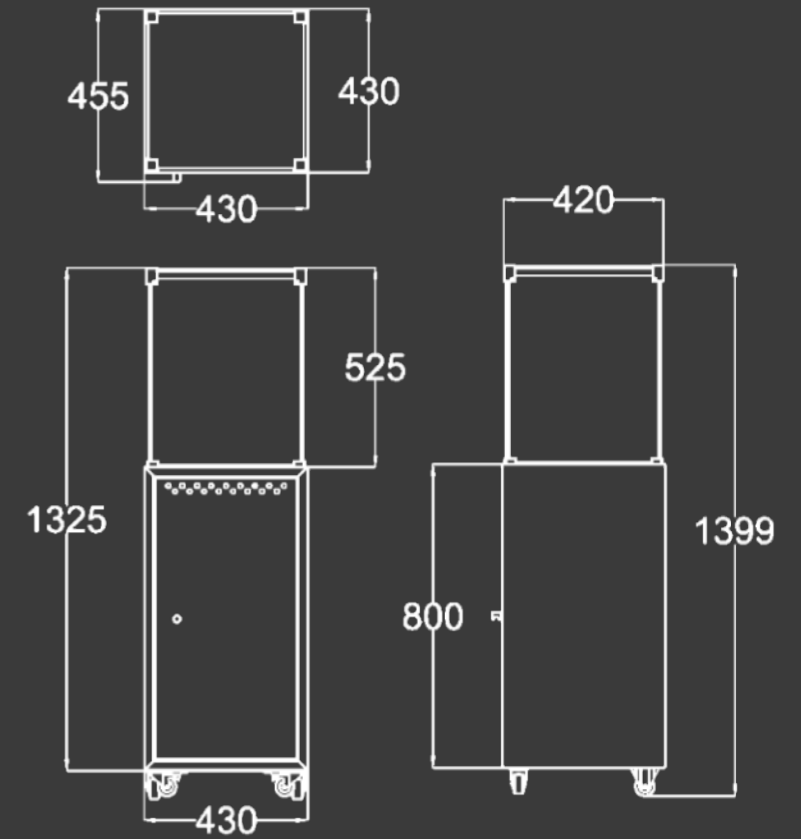

Accessories:

- Volcanic stones: Included.
- Waterproof cover: 49,99€
- Kit hose and regulator: 21,77€



Gas Bottle
11 KG



Duration
25 Hours



Consumption
0,5 KG/Hours



Capacity
7,3 KW



MUZTAG MARBELLA

The Muztag Marbella model presents an industrial, robust, elegant and functional design to be enjoyed all year.

Inside it hides a standard size Propane Gas bottle (11KG), the maximum capacity it can reach is 7.3 KW which allows it to provide an environment full of lighting and a source of heat, in addition the flame can be adjusted, the burner comes with volcanic stones.

For storage or protect the heater in case of rain we offer a waterproof cover that fully protects it.

Price: 849,00€ Taxes included.





Technical Specifications

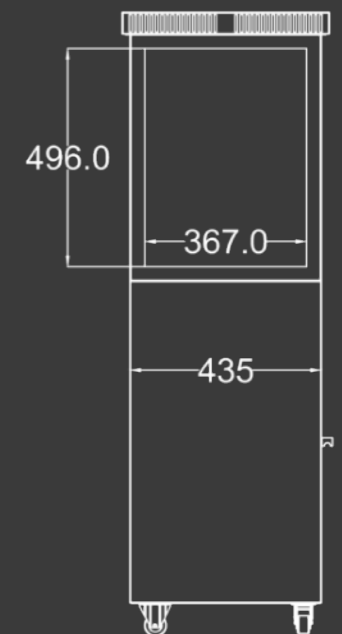
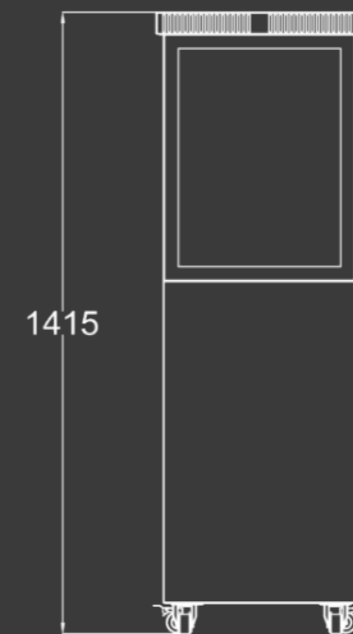
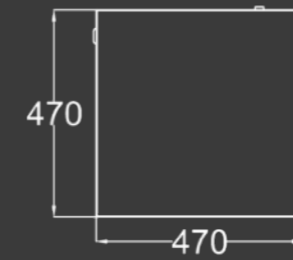

Accessories:

- Volcanic stones: Included.
- Waterproof cover: 49,99€
- Kit hose and regulator: 21,77€



Gas Bottle
11 KG



Duration
25 Hours



Consumption
0,5 KG/Hours



Capacity
7,3 KW

PREMIUM FIRE SINTRA

The Sintra outdoor heater from Premium Fire has an industrial, robust, functional and very portable design which comes in two versions, 3-sided glass and 4-sided glass, in addition of having a rounded top.

The Propane Gas bottle is hidden inside, it is a standard size (11KG) with a maximum capacity of 8.5 KW perfect for the hostelry, in addition it has an adjustable flame and it comes with an artificial log burner which gives it a more traditional touch.

For storage or protect the heater in case of rain we offer a waterproof cover that fully protects it.

Price: 749,00€ Taxes included.





Technical Specifications

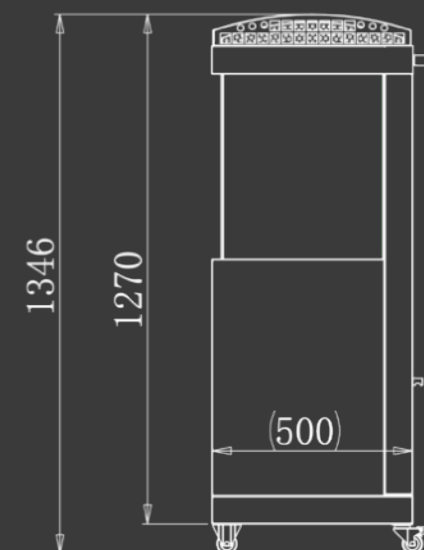
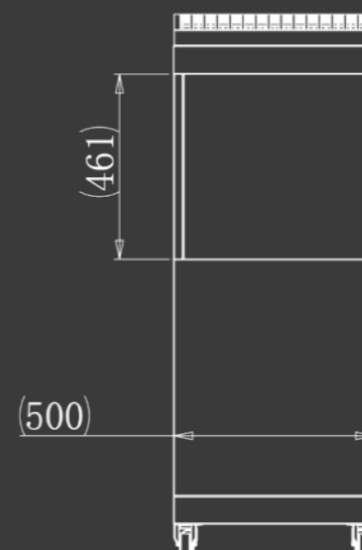
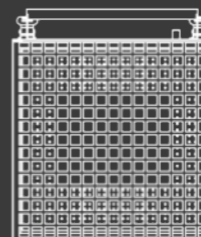

Accessories:

- Volcanic stones: Included.
- Waterproof cover: 49,99€
- Kit hose and regulator: 21,77€



Gas Bottle
11 KG



Duration
20 Hours



Consumption
0,6 KG/Hour



Capacity
8,5 KW

PREMIUM FIRE ROMA

The outdoor heater Premium fire Roma has a resistant, compact, functional design to be enjoyed all year.

Inside it hides a standard size Propane Gas bottle (11KG), the maximum capacity it can reach is 7.3 KW which allows it to provide enough heat to prolong the cool mornings and pleasant summer afternoons, in addition the flame can be adjusted, the burner comes with volcanic stones.

For storage or protect the heater in case of rain we offer a waterproof cover that fully protects it.

Price: 649,00€ Taxes included.





Technical Specifications

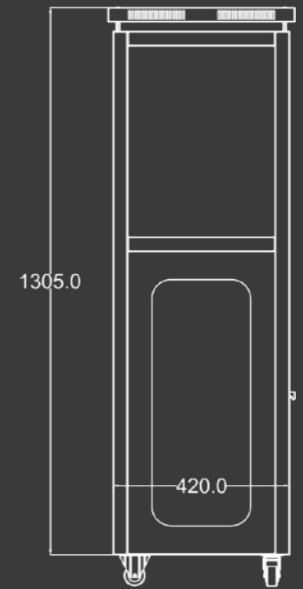
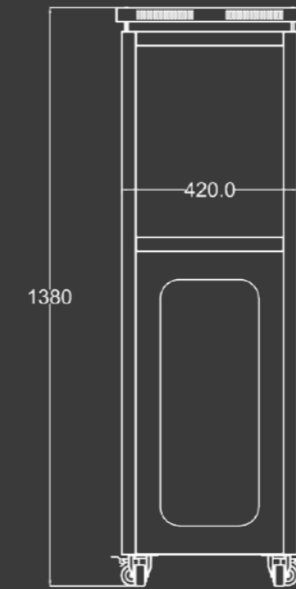
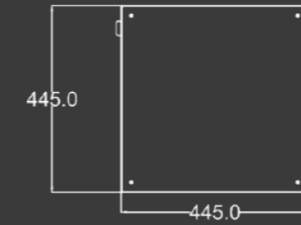

Accessories:

- Volcanic stones: Included.
- Waterproof cover: 49,99€
- Kit hose and regulator: 21,77€



Gas Bottle
11 KG



Duration
25 Hours



Consumption
0,6 KG/Hour



Capacity
7,3 KW

PREMIUM FIRE PARÍS

The outdoor heater Paris from the Premium Fire brand has a compact, elegant, robust and functional design that allows the customer to enjoy it the 365 days of the year.

The Propane Gas bottle is hidden inside, it is a standard size (11KG) with a maximum capacity of 6,5 KW which allows it to provide an environment full of lighting and a source of heat, also the flame can be adjusted, the burner comes with volcanic stones.

For storage or protect the heater in case of rain we offer a waterproof cover that fully protects it.

Price: 599,00€ Taxes included.





Technical Specifications

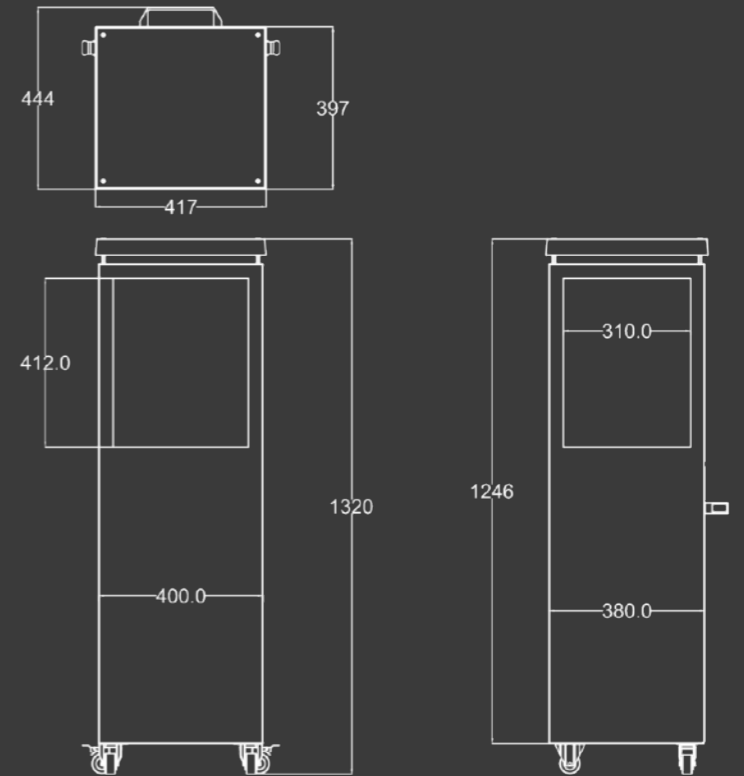

Gas Bottle
11 KG



Duration
28 Hours



Consumption
0,4 KG/Hour



Capacity
6,5 KW

Accessories:

- Volcanic stones: Included.
- Waterproof cover: 49,99€
- Kit hose and regulator: 21,77€

PREMIUM FIRE FARO

The outdoor heater Faro from the Premium Fire brand has an elegant, robust and functional design that allows the customer to enjoy it all year long.

The Propane Gas bottle is hidden inside, it is a standard size (11KG) with a maximum capacity of 6,5 KW which allows it to provide an environment full of lighting and a source of heat, also the flame can be adjusted, the burner comes with volcanic stones.

For storage or protect the heater in case of rain we offer a waterproof cover that fully protects it.

Price: 599,00€ Taxes included.



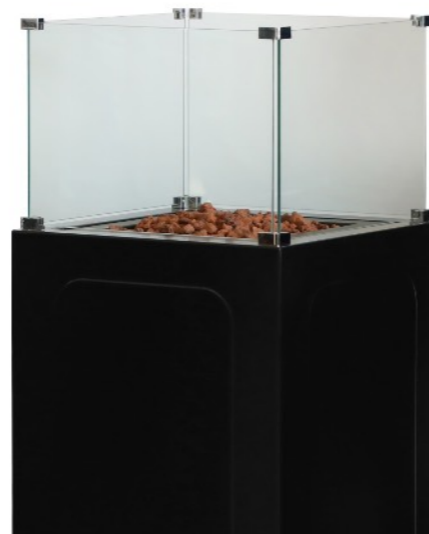

Gas Bottle
11 KG



Duration
28 Hours



Consumption
0,4 KG/Hour



Capacity
6,5 KW

Especificaciones Técnicas

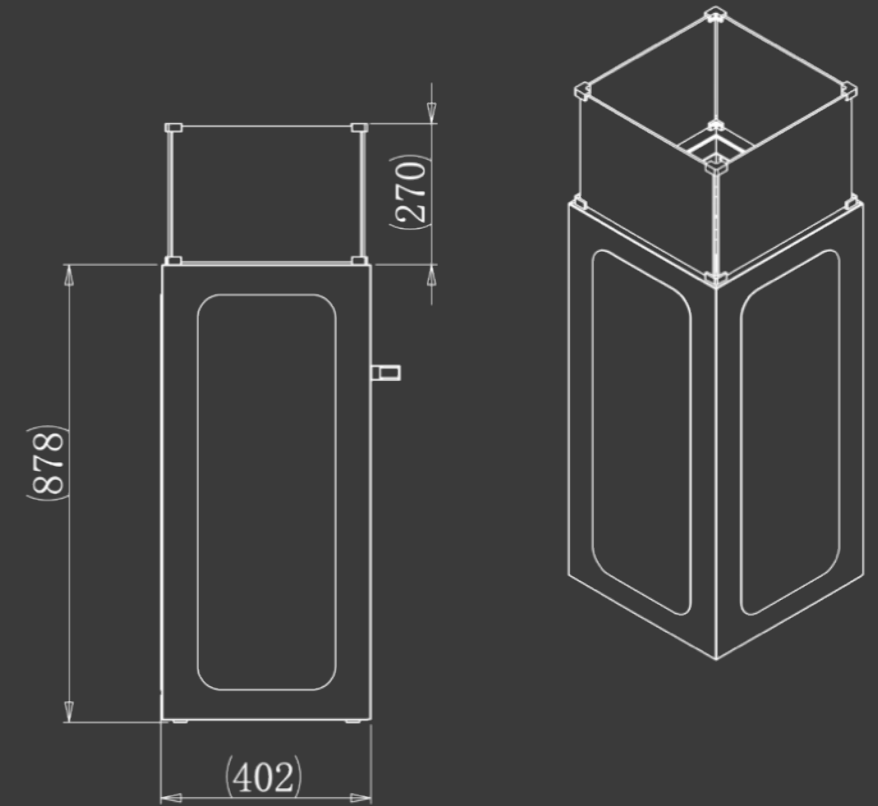

Accessories:

- Volcanic stones: Included.
- Waterproof cover: 49,99€
- Set of 4 wheels: 49,99€
- Kit hose and regulator: 21,77€

PREMIUM FIRE LONDRES

The outdoor fire table Premium Fire Londres will make your terrace stand out thanks to a modern, compact, robust and functional design and thanks to its low weight it's easier to move around.

The Propane Gas bottle is hidden inside, it is a standard size (6KG) with a maximum capacity of 6,5 KW which allows it to provide enough heat to prolong the cool mornings and pleasant summer afternoons, in addition the flame can be adjusted, the burner comes with volcanic stones.

For storage or protect the heater in case of rain we offer a waterproof cover that fully protects it.

Price: 639,00€ Taxes included.





Technical Specifications

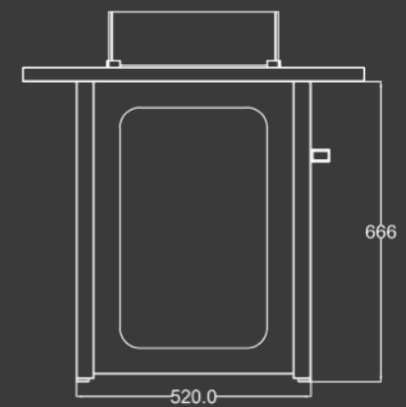
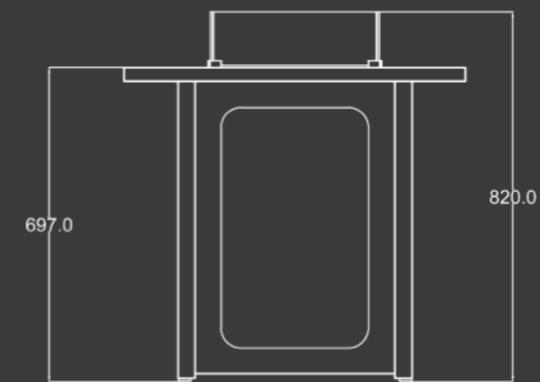
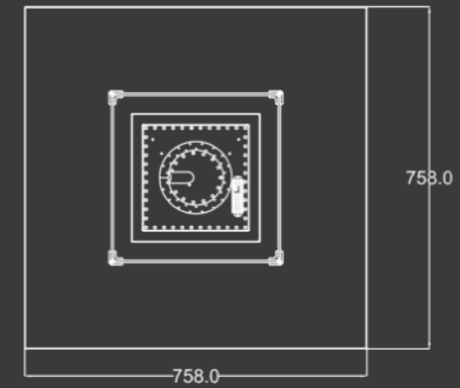

Accessories:

- Volcanic stones: Included.
- Waterproof cover: 49,99€
- Kit hose and regulator: 21,77€



Gas Bottle
6 KG



Duration
15 Hours



Consumption
0,4 KG/Hour



Capacity
6,5 KW

PREMIUM FIRE MADRID

The model Madrid from the Premium Fire brand is an outdoor fire table that will make your terrace or porch a real focus of attention. It features a very compact, modern and elegant design.

The Propane Gas bottle is hidden inside, it is a small size (6KG) with a maximum capacity of 6,5 KW which allows it to providing an environment full of lighting and a source of heat, in addition the flame can be adjusted, the burner comes with volcanic stones.

For storage or protect the heater in case of rain we offer a waterproof cover that fully protects it.

Price: 599,00€ Taxes included.



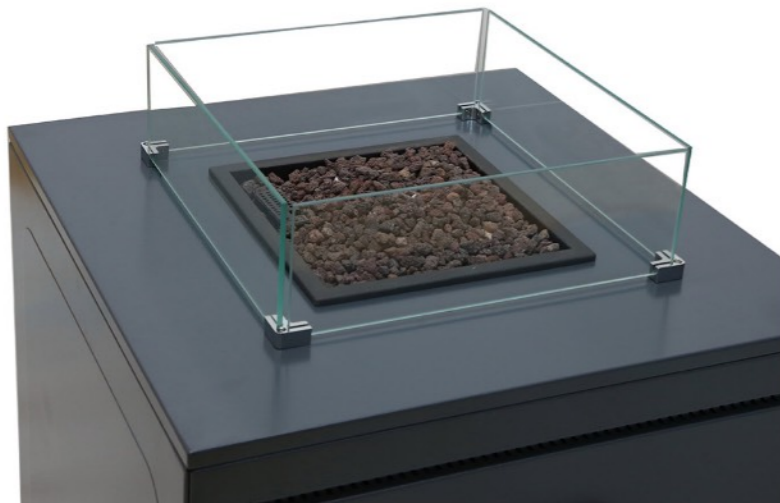

Technical Specifications

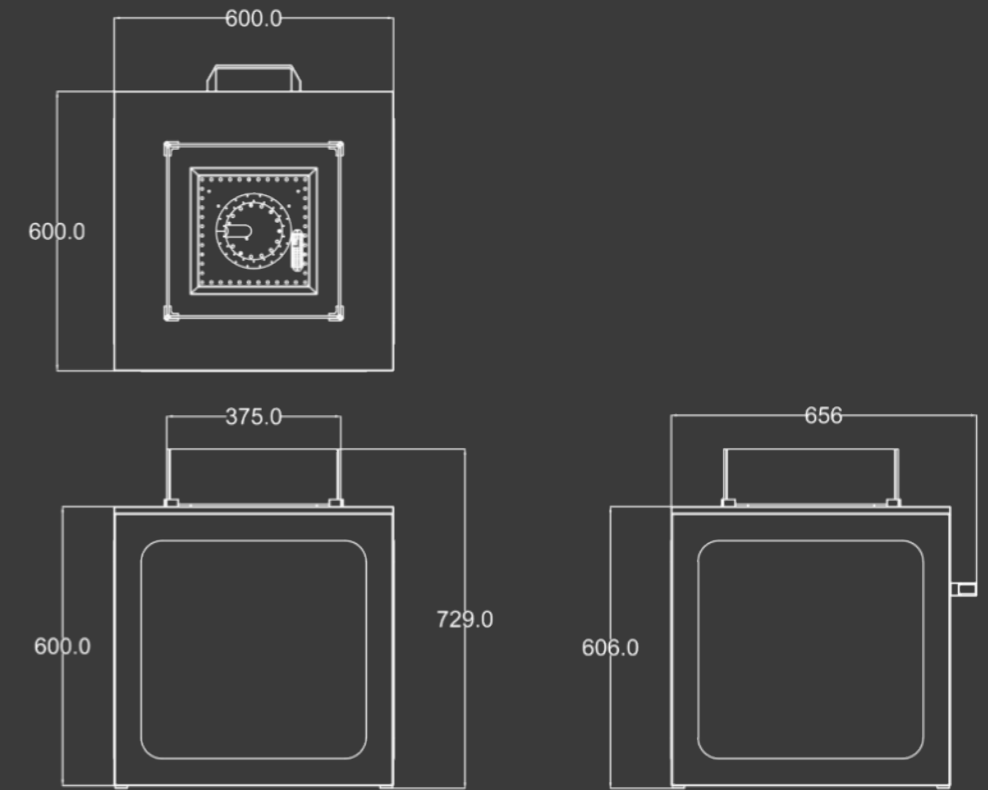

Gas Bottle
6 KG



Duration
15 Hours



Consumption
0,4 KG/Hour



Capacity
6,5 KW

Accessories:

- Volcanic stones: Included.
- Waterproof cover: 49,99€
- Kit hose and regulator: 21,77€



Clima Heating Europe

**Calle Escritora Gertrudis Gómez de Avellaneda N20,
Pol. Industrial Trévenez
29196 Málaga**

+34 - 952 63 35 64 / +34 - 680 331 316

**www.premiumfire.eu
www.muztagestufas.es**